

1X INSERTO PER  
PROFILO 25X25X1.5

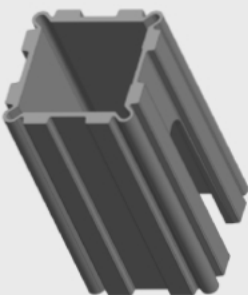

1X G20-1-ASOLA

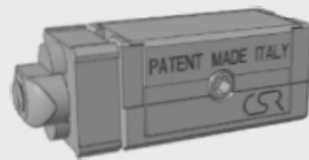

SEZIONE TUBO

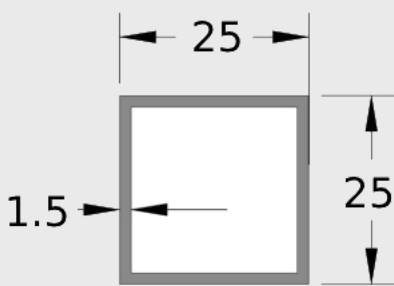

1X - TUBO A

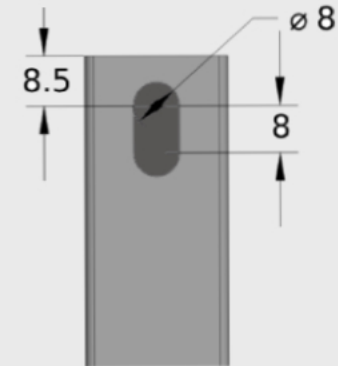

1X - TUBO B

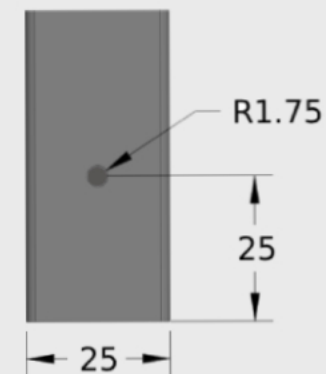

ASSEMBLAGGIO DELLE COMPONENTI:

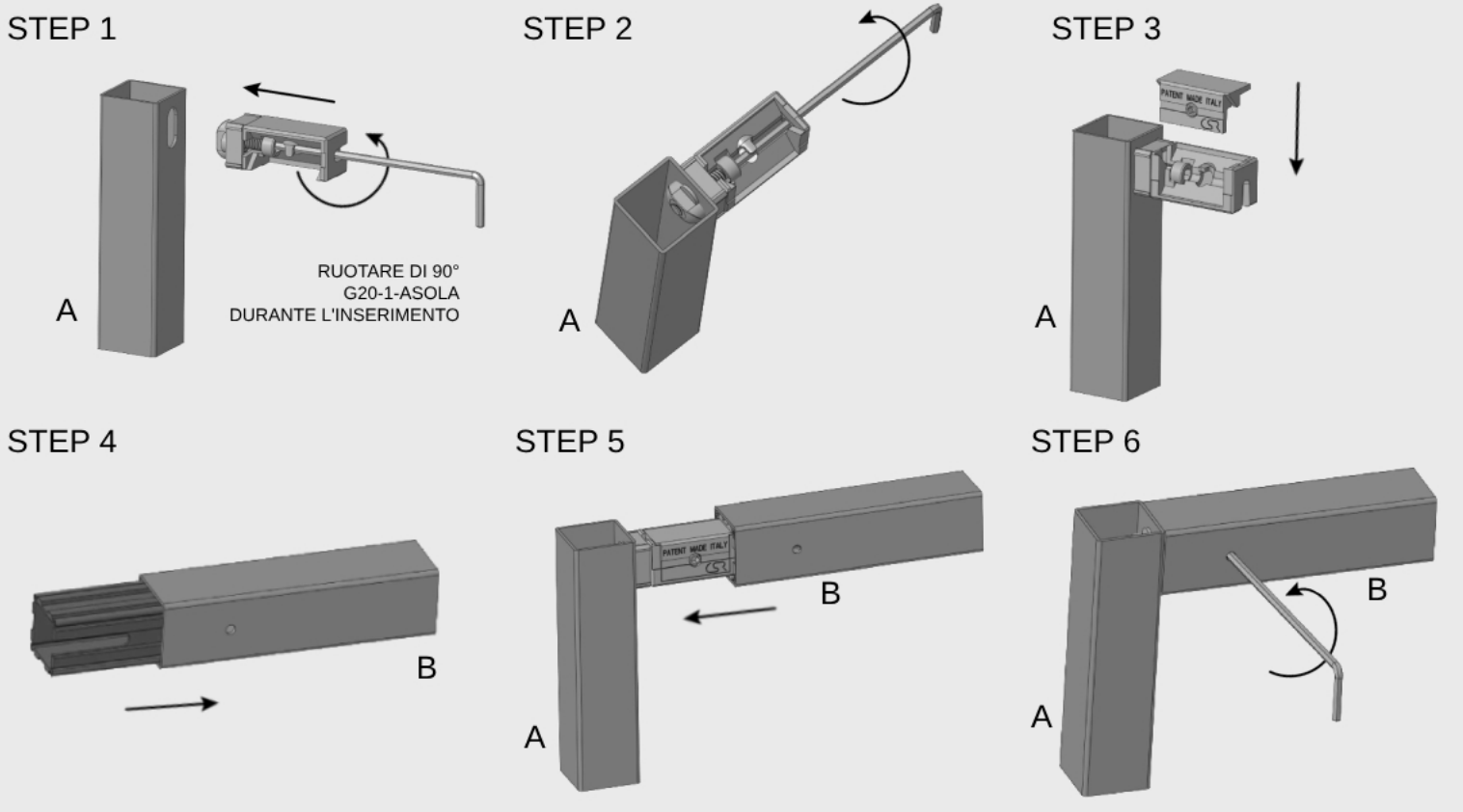

SEZIONE TRASVERSALE:

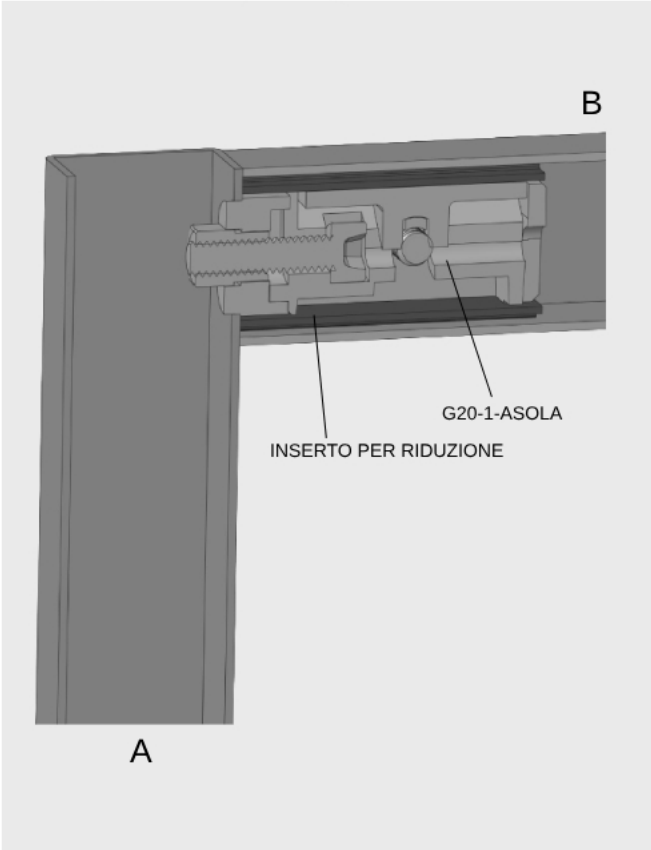

INSERTO RIDUTTORE PER SPESSORE PROFILO 25X25X1.5 MM COD: INSRID-1E5 -  
UTILIZZATO CON GIUNZIONE 20X20 A 1 VIA COD: G20-1-ASOLA

1X INSERTO PER  
PROFILO 25X25X1.5

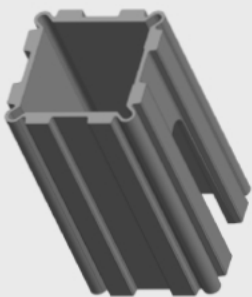

1X G20-20-2SI

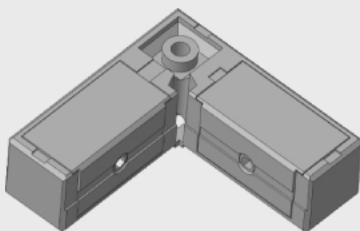

SEZIONE TUBO

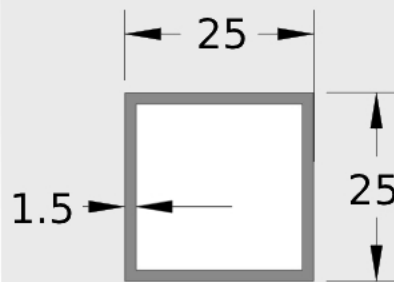

2X - TUBO A

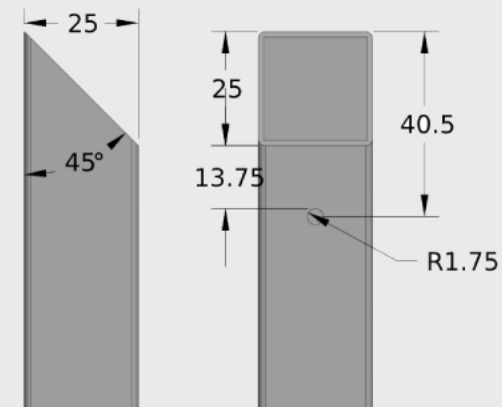

ASSEMBLAGGIO DELLE COMPONENTI:

STEP 1

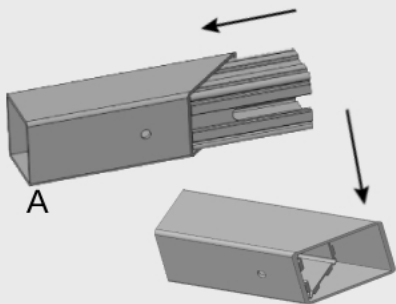

INSERIRE L'INSERTO  
COME DA IMMAGINE

STEP 2

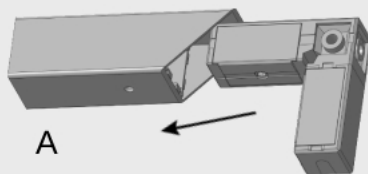

STEP 4

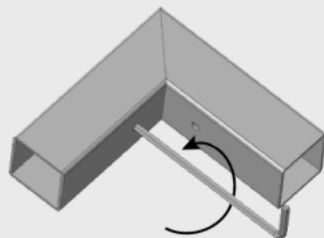

CHIUDERE ENTRAMBI  
I GRANI CON LA BRUGOLA

SEZIONE TRASVERSALE:

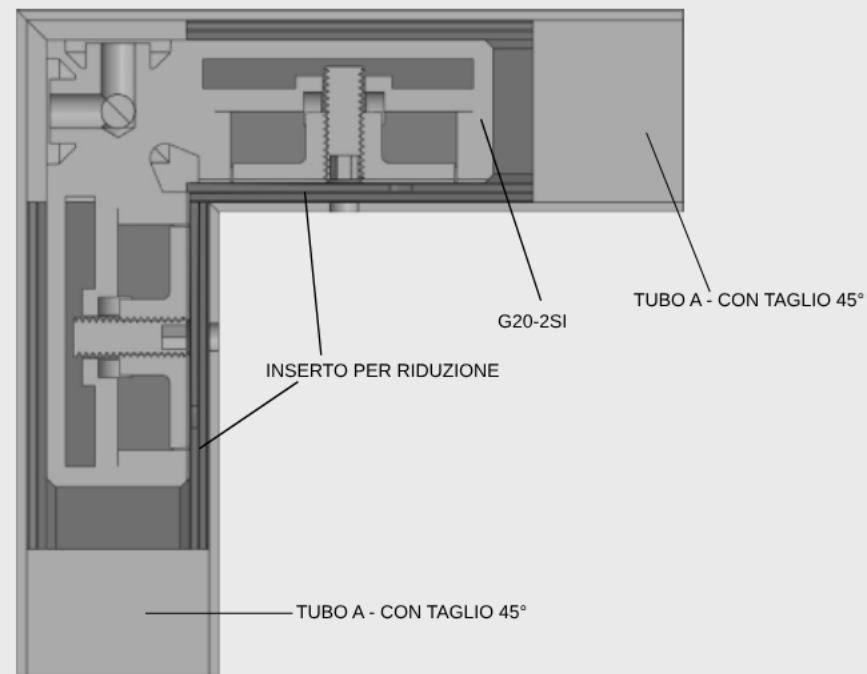

INSERTO RIDUTTORE PER SPESSORE PROFILO 25X25X1.5 MM COD: INSRID-1E5 -  
UTILIZZATO CON GIUNZIONE A SCOMPARSA 20X20 A 2 VIE COD: G20-2-SI

1X INSERTO PER  
PROFILO 25X25X1.5

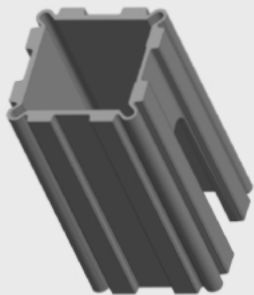

1X G20-20-3SI

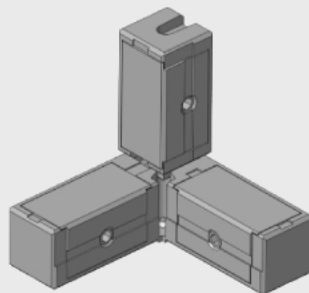

SEZIONE TUBO

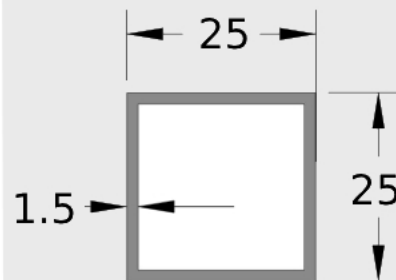

1X - TUBO B-B2-C

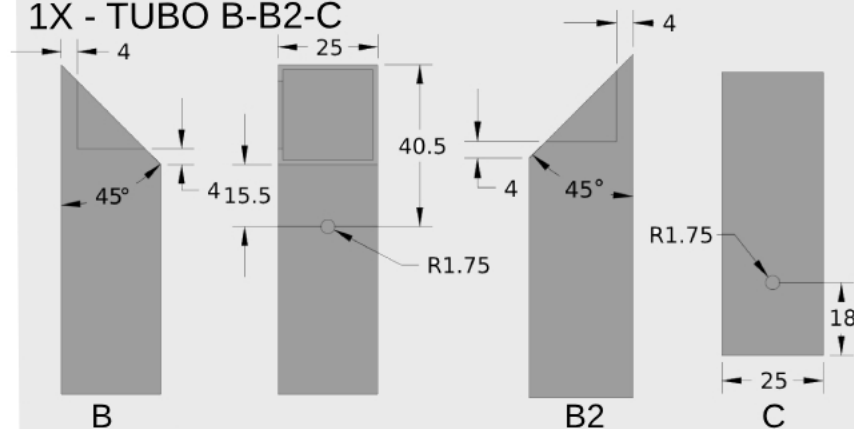

ASSEMBLAGGIO DELLE COMPONENTI:

STEP 1

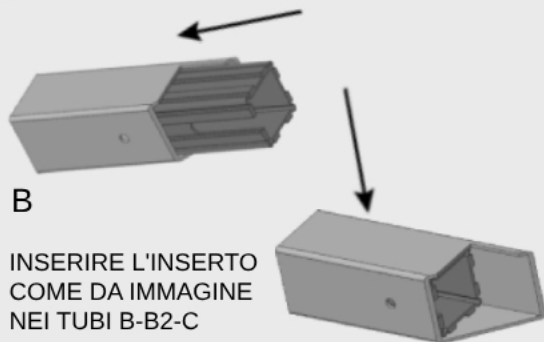

STEP 2

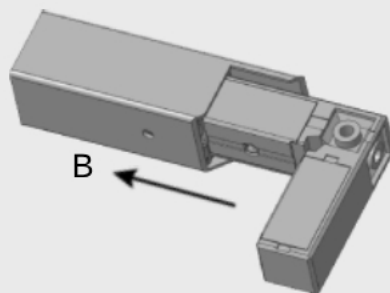

STEP 3

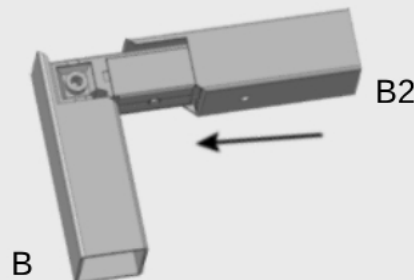

STEP 4

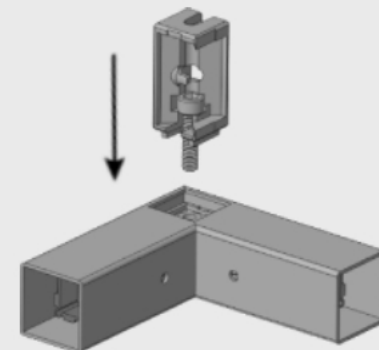

STEP 5

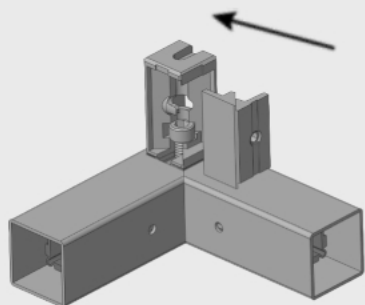

STEP 6

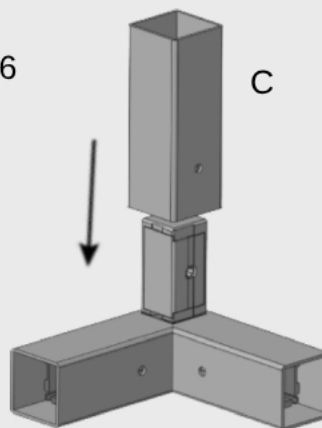

STEP 7

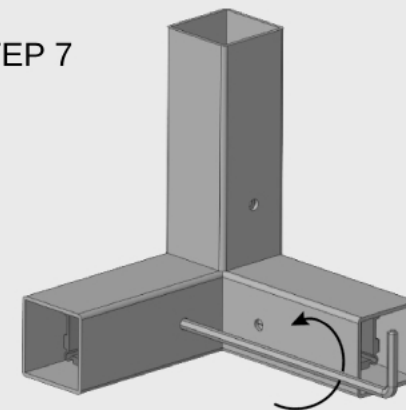

CHIUDERE I 3 GRANI  
CON LA BRUGOLA



INSERTO RIDUTTORE PER SPESSORE PROFILO 25X25X1.5 MM COD: INSRID-1E5 -  
UTILIZZATO CON GIUNZIONE A SCOMPARSA 20X20 A 3 VIE COD: G20-3-SI